

STEP 1 PRIORITY

REFERENCE POLYGUARD 650 MEMBRANE BOOT FOR POLYGUARD UNDERSLAB UNDERSLAB INSIDE CORNER DETAIL

NOTE:
PURCHASE PREFORMED BOOTS OR FIELD FABRICATE USING POLYGUARD 650 MEMBRANE BOOT DETAIL FOR POLYGUARD UNDERSLAB INSIDE CORNER - BUT THIS STEP IS A CRITICAL STEP THAT MUST BE DONE PRIOR TO PLACING THE POLYGUARD UNDERSLAB MEMBRANE - OMITTING THIS STEP VOIDS THE WARRANTY

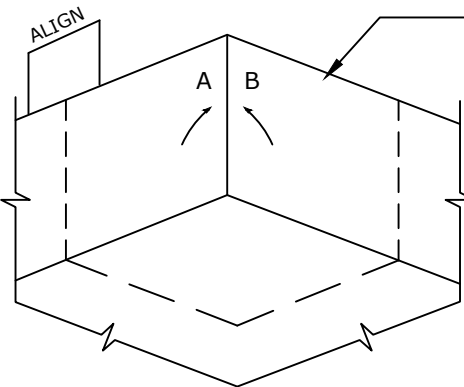

STEP 3

POSITION THE CUT POLYGUARD UNDERSLAB MEMBRANE INTO THE CORNER AND OVER THE BOOT SO THE (A) AND (B) EDGES MEET IN THE VERTICAL LEG OF THE BOOT. FORM-FIT THE PIECE TO THE CONTOURS OF THE CORNER. CREASE THE POLYGUARD UNDERSLAB MATERIAL TO ESTABLISH A CONFORMING SHAPE. AFTER CREASING, FOLD THE PIECE BACK, REMOVE THE RELEASE PAPER FROM THE HORIZONTAL LEG OF THE BOOT, THEN OVERLAY AND PRESS THE HORIZONTAL LEG INTO THE BOOT. REPEAT FOR EACH VERTICAL LEG.

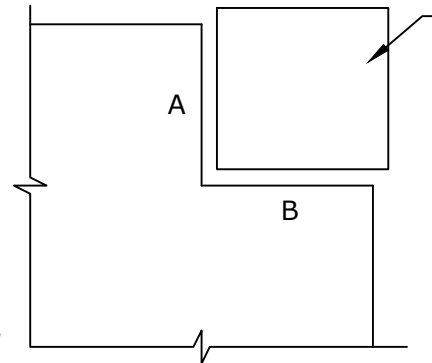

STEP 2

CUT AND REMOVE A SQUARE PIECE OF POLYGUARD UNDERSLAB MEMBRANE FROM THE END CORNER. CUTOUT IS DETERMINED BY THE HEIGHT OF THE CONCRETE FORM. (EX: 12" FORM WOULD BE A 12" X 12" CUT OUT) DIMENSION THE STARTING POINT OF EACH CUT FROM THE CORNER, AND ALONG AN EDGE, A DISTANCE EQUAL TO THE HEIGHT OF THE VERTICAL LEG OF THE BOOT.

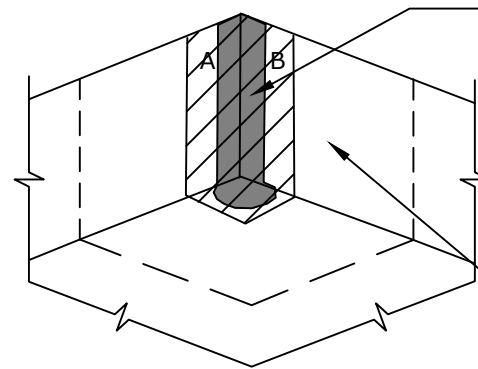

STEP 4 & 5

PREPARE THE FABRIC ALONG THE (A) AND (B) EDGES WITH POLYGUARD 650 LT LIQUID ADHESIVE OR POLYGUARD CALIFORNIA SEALANT APPLIED AT A RATE OF 50 - 75 SF/GAL. SEAL THE (A) AND (B) EDGES AND BOTTOM CORNER USING A MINIMUM 90 MIL THICKNESS BY 2" WIDE APPLICATION OF POLYGUARD LM-95 TROWELED ONTO EACH LEG AND JOINED AT THE INTERSECTING PLANES.

CUT AND APPLY POLYGUARD FABRIC TAPE TIGHTLY OVER THE CURED POLYGUARD LM-95 AND POLYGUARD UNDERSLAB MEMBRANE - PREPARE THE FABRIC WITH POLYGUARD 650 LT LIQUID ADHESIVE OR POLYGUARD CALIFORNIA SEALANT APPLIED AT A RATE OF 50 - 75 SF/GAL.

US11

SECTION @ INSIDE CORNER DETAIL

<small>The information provided is based on data and knowledge considered to be true and accurate and is offered for the users' consideration, investigation and verification, but we do not warrant the results to be obtained. Please read all data sheets, statements, recommendations or suggestions in conjunction with our conditions of sale, which apply to all goods supplied by us.</small>	NOT TO SCALE
	EFFECTIVE DATE: 10/01/2022
	SUPERCEDES: 02/01/2022