

STEP 1 PRIORITY

POLYGUARD UNDERSEAL (US) PREFORMED INSIDE CORNER BOOT (12 X 12 X 12) INTO CORNER WITH POLYETHYLENE SIDE INTERFACING WITH CONCRETE FORM OR WALL. REFERENCE POLYGUARD UNDERSLAB TRM INSIDE CORNER BOOT STANDARD DETAIL (TU20) PRIOR TO STARTING THIS INSIDE CORNER DETAIL.

GENERAL NOTE:
PURCHASE POLYGUARD US PREFORMED INSIDE CORNER BOOT, OR FIELD FABRICATE USING POLYGUARD 650 TRM BOOT STANDARD DETAIL (TU20) FOR POLYGUARD UNDERSLAB TRM INSIDE CORNER - THIS STEP IS A CRITICAL STEP THAT MUST BE DONE PRIOR TO PLACING POLYGUARD UNDERSLAB TRM - OMITTING THIS STEP VOIDS WARRANTY

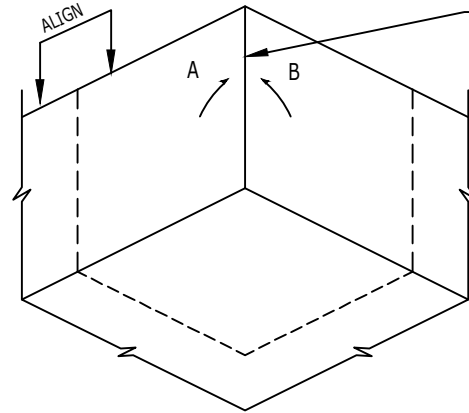

POSITION CUT POLYGUARD UNDERSLAB TRM INTO CORNER AND OVER POLYGUARD INSIDE CORNER BOOT SO (A) AND (B) EDGES MEET IN VERTICAL LEG OF BOOT; FORM-FIT PIECE TO CORNER CONTOURS. CREASE POLYGUARD UNDERSLAB TRM TO ESTABLISH A CONFORMING SHAPE. AFTER CREATING, FOLD PIECE BACK, REMOVE RELEASE PAPER FROM INSIDE CORNER BOOT HORIZONTAL LEG, THEN OVERLAY AND PRESS UNDERSLAB TRM HORIZONTAL LEG INTO BOOT; REPEAT FOR EACH VERTICAL LEG.

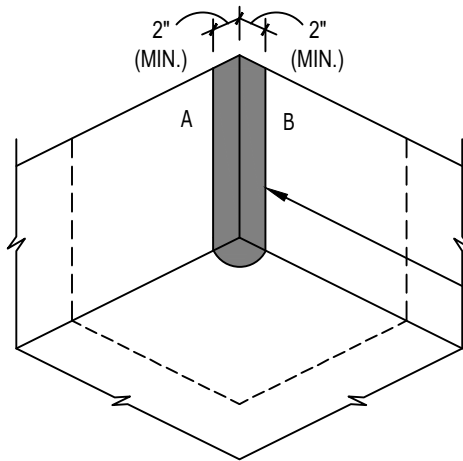

STEP 3

PREPARE POLYGUARD UNDERSLAB TERM WATER / TERMITE BARRIER MEMBRANE FABRIC ALONG (A) AND (B) EDGES WITH POLYGUARD 650 LT LIQUID ADHESIVE OR CALIFORNIA SEALANT APPLIED AT A RATE OF 50 - 75 SF / GAL PRIOR TO SEALING (A) AND (B) EDGES AND BOTTOM CORNER WITH POLYGUARD LM-95 OR TRM SEALANT APPLIED AND TOOLED TO MINIMUM 90 MILS BY 2" WIDE APPLICATION ONTO EACH LEG AND JOINED AT INTERSECTING PLANES.

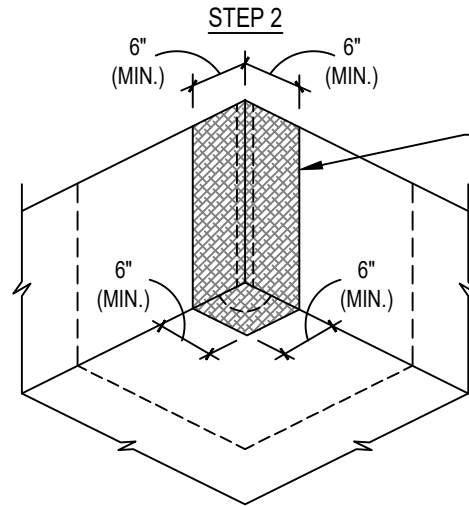

STEP 4

POLYGUARD FABRIC TAPE APPLIED TIGHTLY OVER CURED POLYGUARD TRM SEALANT AND POLYGUARD UNDERSLAB TRM FABRIC PREPARED WITH POLYGUARD 650 LT LIQUID ADHESIVE OR CALIFORNIA SEALANT APPLIED AT A RATE OF 50 - 75 SF / GAL

UST11

ISOMETRIC @ UNDERSLAB TRM - INSIDE CORNER (STEPS)

The information provided is based on data and knowledge considered to be true and accurate and is offered for the users' consideration, investigation and verification, but we do not warrant the results to be obtained. Please read all data sheets, statements, recommendations or suggestions in conjunction with our conditions of sale, which apply to all goods supplied by us.	NOT TO SCALE
	EFFECTIVE DATE: 12/17/2024
	SUPERCEDES: 12/05/2024