

- 3 TERM[®] UNDERSLAB WATERPROOFING / TERMITE BARRIER APPLIED TO THE LEFT LEG OF THE CORNER AND CUT FLUSH ALONG THE CORNER EDGE TO FORM A LEG THAT WILL LAY FLAT ALONG THE HORIZONTAL PLANE OF THE RIGHT LEG A DISTANCE OF 4" AND WILL CONTINUE BEYOND THE CORNER A MINIMUM DISTANCE OF 4"
- 1 6" WIDE TERM[®] 606 DOUBLE-SIDED TAPE BARRIER TOP EDGE ALIGNED WITH WHERE THE TOP EDGE OF THE BOOT WILL BE AND APPLIED OVER A PREPARED CONCRETE SUBSTRATE COATED WITH 650 LT LIQUID ADHESIVE OR CALIFORNIA SEALANT APPLIED AT 250-300 SF/GAL
- 2 TERM[®] UNDERSLAB PREFORMED OUTSIDE CORNER BOOT

IMAGE 1

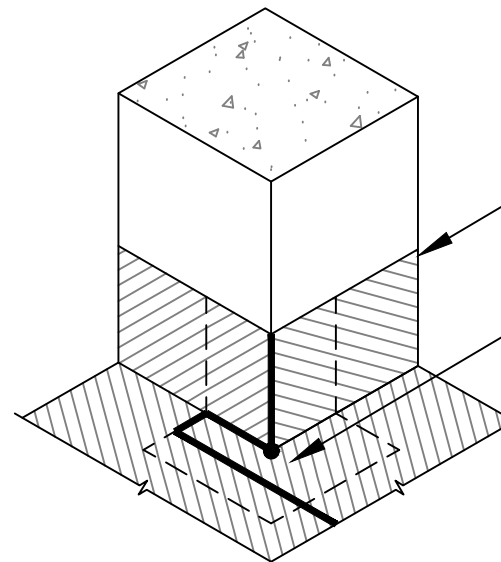

- 4 TERM[®] UNDERSLAB WATERPROOFING / TERMITE BARRIER APPLIED TO THE RIGHT LEG OF THE CORNER AND TRIMMED TO ABOUT THE LEFT LEG END CUT
- 5 POLYGUARD DETAIL SEALANT PW[™] APPLIED OVER THE CORNER AND EDGE CUTS PREPARED WITH 650 LT LIQUID ADHESIVE OR CALIFORNIA SEALANT APPLIED AT A RATE OF 100-150 SF/GAL. APPLY AN EXTRA 1/2" DAUB AT THE POINT INTERSECTION COMMON TO EACH LEG AND THE HORIZONTAL PLANE

IMAGE 2

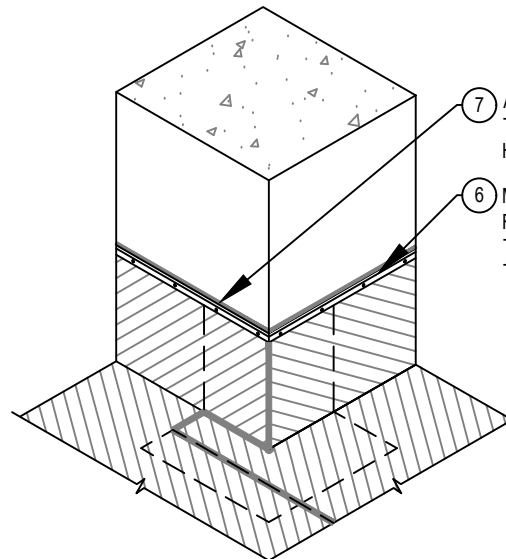

- 7 APPLY 3/8" INCH BEAD OF DETAIL SEALANT PW[™] ALONG TOP EDGE OF TERMINATION AND OVER EACH FASTENER HEAD EXTENDING 1/8" BEYOND HEAD OF FASTENER
- 6 MINIMUM 1/8" X 1" METAL TERMINATION BAR, START FASTENERS 2" FROM CORNER WITH 6" SPACING TO THE 2'-0" MARK. CONTINUE FASTENER SPACING FROM THAT POINT AT 12" O.C.

IMAGE 3

TERM[®] UNDERSLAB WATERPROOFING / TERMITE BARRIER PREFORMED OUTSIDE CORNER AT A COLUMN

TU17

© POLYGUARD PRODUCTS, INC.

P.O. Box 755 - Ennis, TX 75120
 Phone: 214-515-5000 Fax: 972-875-9425
 Web Site - www.polyguardbarriers.com



polyguard
 TERM BARRIER

The information provided is based on data and knowledge considered to be true and accurate and is offered for the users' consideration, investigation, and verification; but we do not warrant the results to be achieved. Please read all data sheets, statements, suggestions, or recommendations in conjunction with our conditions of sale, which apply to all goods supplied by us.

DRAWING SCALE:	NOT TO SCALE
EFFECTIVE DATE:	03/01/2018
SUPERCEDES:	05/18/2017